

WHEELJOCKEY®

JOCJR.

Using the Wheel Jockey®

For use on road motorcycles up to 450 lbs. Not for use on off-road tires.

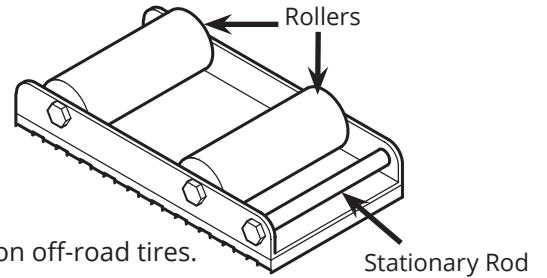

1

Begin with the motorcycle on level ground. Be sure the side stand is in the "down" position and the bike is leaning on the stand.

With the bike still on the side stand, position the Wheel Jockey 2" in front of the rear wheel, with the smaller, stationary rod end pointing toward the wheel.

NOTE: Some bikes benefit from a 1.5" block under the side stand. Correct tire pressure is essential for ease of operation.

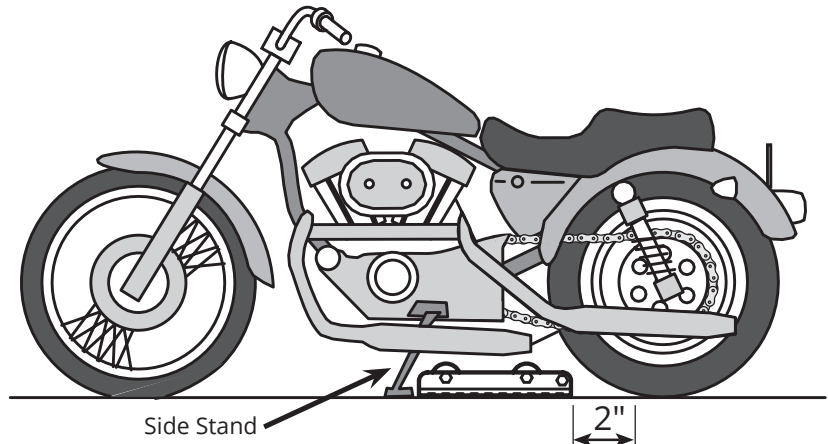

2

Bring the bike upright and slowly roll it forward onto the Wheel Jockey until the wheel is positioned in the center of the two rollers.

Once in position, hold the bike in place with the front brake and carefully lean the bike back onto the side stand. Make sure the wheel remains centered over the rollers and the bike is stable.

NOTE: At first, you may roll right over the top of the Wheel Jockey, or you may find it difficult to get the wheel centered on the Wheel Jockey. However, once you determine where to position the Wheel Jockey for your bike's wheel, it becomes very easy.

You may now clean the wheel, inspect the tire, locate the valve stem, and perform chain maintenance by rotating the wheel on the rollers. Slowly turn the wheel using the spokes; keep tire centered on the rollers. Heavier bikes can make it harder to turn the wheel.

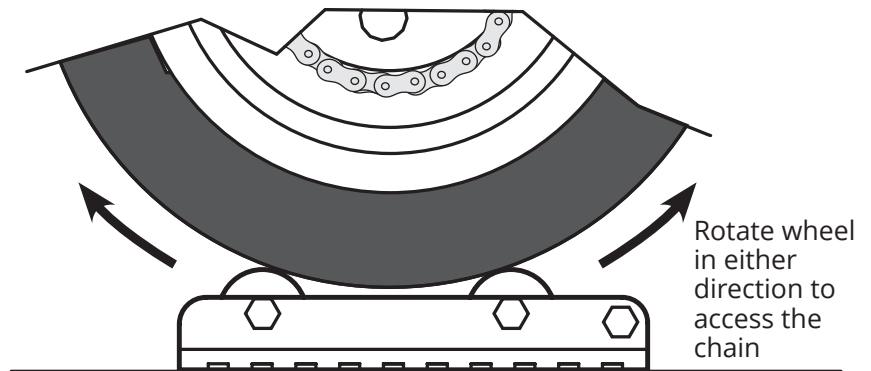

3

When cleaning and maintenance is complete, once again stand the bike vertically and roll it forward off the Wheel Jockey.

Return the bike to rest on the side stand.

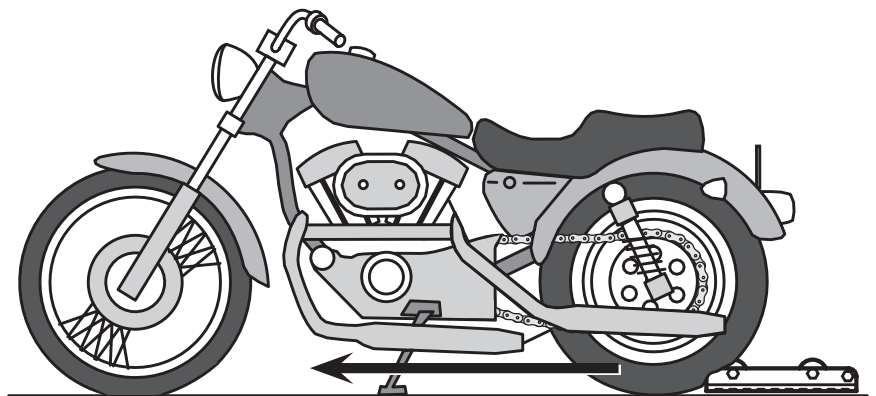

Rules of the Road When Using Wheel Jockey®

- Always exercise caution and common sense
- Make sure the motorcycle engine is switched off at all times
- Always try and keep one hand on the bike when rotating the wheel
- When possible, enlist the aid of a friend to help further stabilize the bike

www.wheeljockey.com

(704) 256-4049